

USFilter

STRANCO PRODUCTS

POLYBLEND® DP SERIES

POLYMER FEED SYSTEM

USFilter
Taking care of the world's water.

Stranco Products
P.O. Box 389
Bradley, IL 60915 U.S.A.
800.882.6466 *tel*
815.932.8154 *tel*
815.939.9845 *fax*
<http://www.stranco.com>

Priory Works, Tonbridge
Kent, TN11 0QL
United Kingdom
44.1732.354888 *tel*
44.1732.543222 *fax*

Lit No. 1305-9909

THE FINEST DRY POLYMER
FEED SYSTEM

“The USFilter’s Stranco® Products dry polymer feed system is a ‘jewel’ from the operators’ perspective. The operators learned rapidly and feel very comfortable with the principles of its operation. Polymer batches are replicated very closely, and the operators have not experienced variations in centrifuge performance due to unadjusted changes in polymer concentration.”

**Wastewater Treatment
Facility Operator**



DRY DISPERSER SKID

Can be equipped for liquid polymer.

**LOW ENERGY MIX TANK WITH
FEED TANK**

Tank sizes vary based on consumption rates.

FINAL FEED SKID

Final feed skids are designed around your needs. Choose the pumps (number, type and size), the controls (manual, flow pacing, loss of flow, etc.), the materials of construction and type of post-dilution.

**UNMATCHED PERFORMANCE
AND RELIABILITY**

The PolyBlend® DP Series is without question the finest dry polymer feed system available. It outperforms all other designs in head-to-head trials. The DP Series typically reduces polymer consumption 25% or more while substantially improving polymer performance in terms of sludge dryness, solids capture, water clarity, drainage/retention, or any other mea-

sure. Moreover, the PolyBlend DP Series has an unmatched reputation for reliability. While dry polymer feed systems are notoriously high maintenance items, the PolyBlend DP Series requires the least maintenance and operates unattended for longer intervals than any other dry polymer feed system.

**REDUCED POLYMER CONSUMPTION
AND IMPROVED SAFETY**

Dissolving dry polymer in water for use in a clarifier or dewatering device is one of the most difficult tasks in chemical feed technology. Dry polymer particles are typically 100 times larger than the particles of polymer suspended in liquid polymers. Consequently, dry polymer has a greater tendency to agglomerate and requires far more mixing time than liquid polymer. During the

extended mixing time, the polymer is subject to damage from the rotating mixer. In most systems, 1/4 of the polymer is wasted in the form of “fisheyes” or broken into useless fragments. In addition, most dry polymer feed systems are housekeeping nightmares. They are not only unsightly, but can be very dangerous as spilled dry polymer can become a safety hazard.

THE PROCESS

The PolyBlend DP Series overcomes all these difficulties with several patented innovations. The high energy disperser, low energy mix tank, and dry disperser skid are described in detail in the following pages.

Polymer and water come together in the disperser; the solution then moves to the mix tank. From the mix tank, the polymer is sent to a holding tank and from there, through the final feed skid to the point of application. The

operation is fully automatic – all the operator has to do is keep polymer in the hopper.

The control system for the DP Series is unmatched in simplicity. A single LCD display enables complete operation of all functions. Trouble-shooting is also streamlined, with all alarm conditions described on the display. In field trials and start-ups, operators are interfacing with the system worry-free within a half-day of installation.

HIGH ENERGY
MECHANICAL MIXING

To create the ideal environment for the first stage of polymer dissolution, crucial initial wetting occurs in the disperser. Here, polymer and water are subjected to high energy created by mechanical mixing. After brief exposure, the solution exits the high energy disperser.

1. **ISOLATION VALVE**
Prevents moisture contamination of dry powder.
2. **CONTROL BAFFLE**
Creates optimum height for "liquid funnel".
3. **DRY/LIQUID INTERFACE**
Creates optimum environment for introducing dry powder and creating a homogeneous solution.
4. **DILUTION WATER INLET**
5. **MIXING IMPELLER**
Creates a vacuum and provides the initial high energy mix necessary to prevent agglomerations.
6. **STAINLESS STEEL CORROSION RESISTANT CONSTRUCTION**
7. **ACRYLIC COVER**
8. **DRY POWDER FEEDER**
Accurately meters dry powder for consistent solution concentration.
9. **"LIQUID FUNNEL" WATER INLET**
Creates a self-cleaning water funnel which prevents build-up on stationary surfaces.
10. **SOLUTION DISCHARGE TO MIX TANK**
11. **HIGH ENERGY MIXING**
After passing the impeller, the solution moves up and around the vortex guide before exit.
12. **VORTEX GUIDE TUBE**
Draws the contents of dry/liquid interface into high shear mixing impeller.

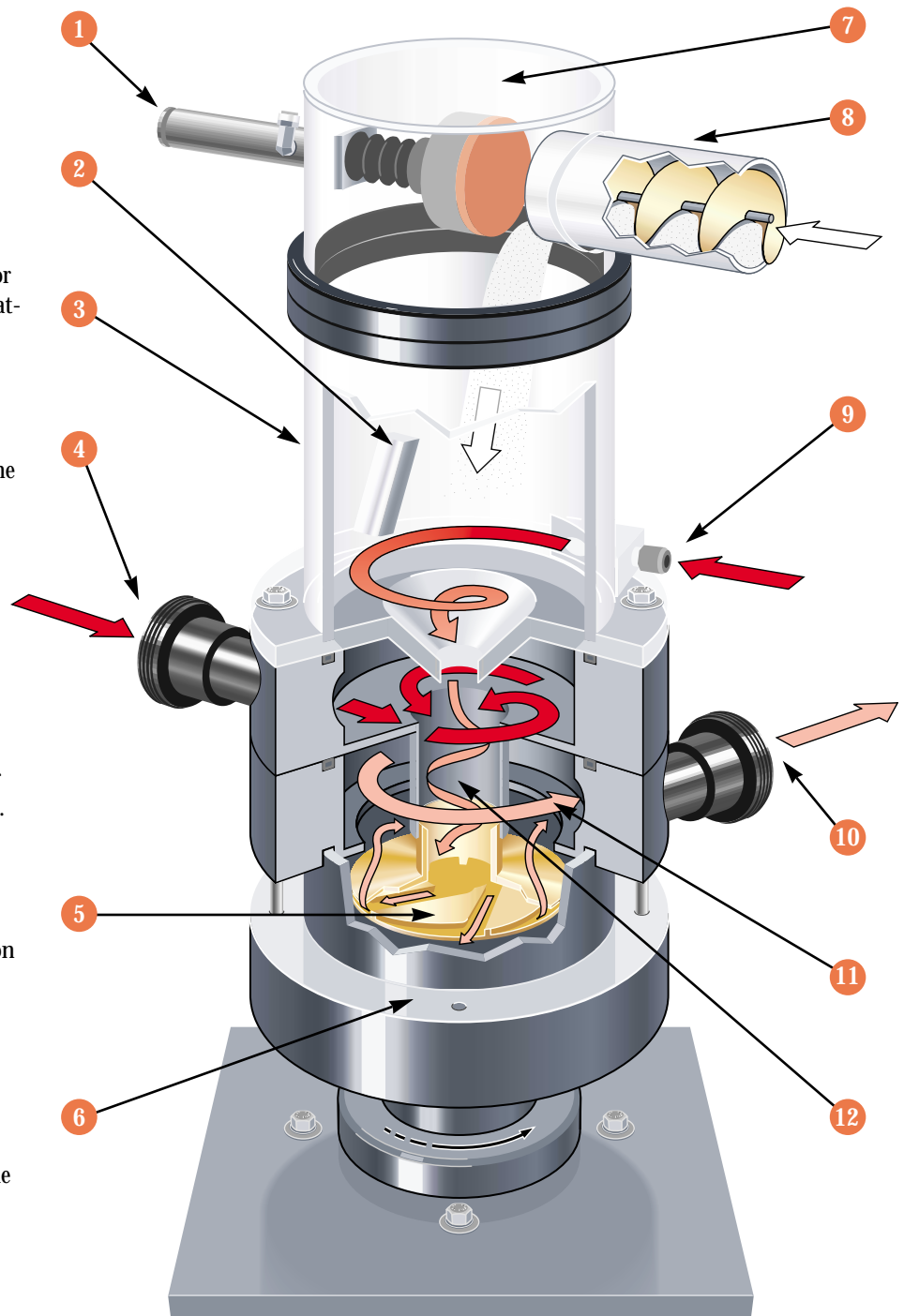

POLYMER COSTS REDUCED
AND PERFORMANCE IMPROVED

1. RIGHT ANGLE GEAR REDUCER

Provides optimum RPM for tank mixing.

2. SOLUTION INLET PIPING

Directs solution into the eye of the “hollow wing” impeller.

3. PATENTED STAINLESS STEEL “HOLLOW WING” MIXING IMPELLER

Reduces polymer consumption by providing proper energy at low speed through impeller size and recirculation to prevent agglomerations, while minimizing polymer fracture.

4. MIX TANK

Corrosion resistant stainless steel or fiberglass square tank design: Improves mixing performance at low speed, allowing activation to continue without damaging the polymer.

5. FEED TANK

Allows continuous solution feed.

6. MIXER MOTOR

Wash-down duty provides reliable operation in harsh conditions.

7. SOLUTION MOVEMENT

Solution is dispersed through the ends of the impeller, and returns after rolling up the sides of the tank and back down.

8. RECIRCULATION PORT

Over-sized impeller opening creates recirculation by pulling solution from inlet piping and tank.

From the disperser, the polymer solution flows into the mix tank. Most polymer mix tanks are not uniform in their mixing energy. Agglomerations form in the portions of the tank that receive the least mixing energy while polymer chains are broken up at the tip of the rotating mixing blade. In contrast, the DP Series tank is specifically designed to be fully uniform in mixing intensity. The rotating impeller is a “hollow wing”, the length of which is over half the width of the tank. The hydraulics of the system make the impeller act like a pump, continuously moving the solution vertically as well as horizontally. Moreover, the square tank design further contributes to uniformity of the mixing energy. The result is no agglomerations and no broken polymer chains. In other words, no waste. Polymer costs are reduced and performance improved.

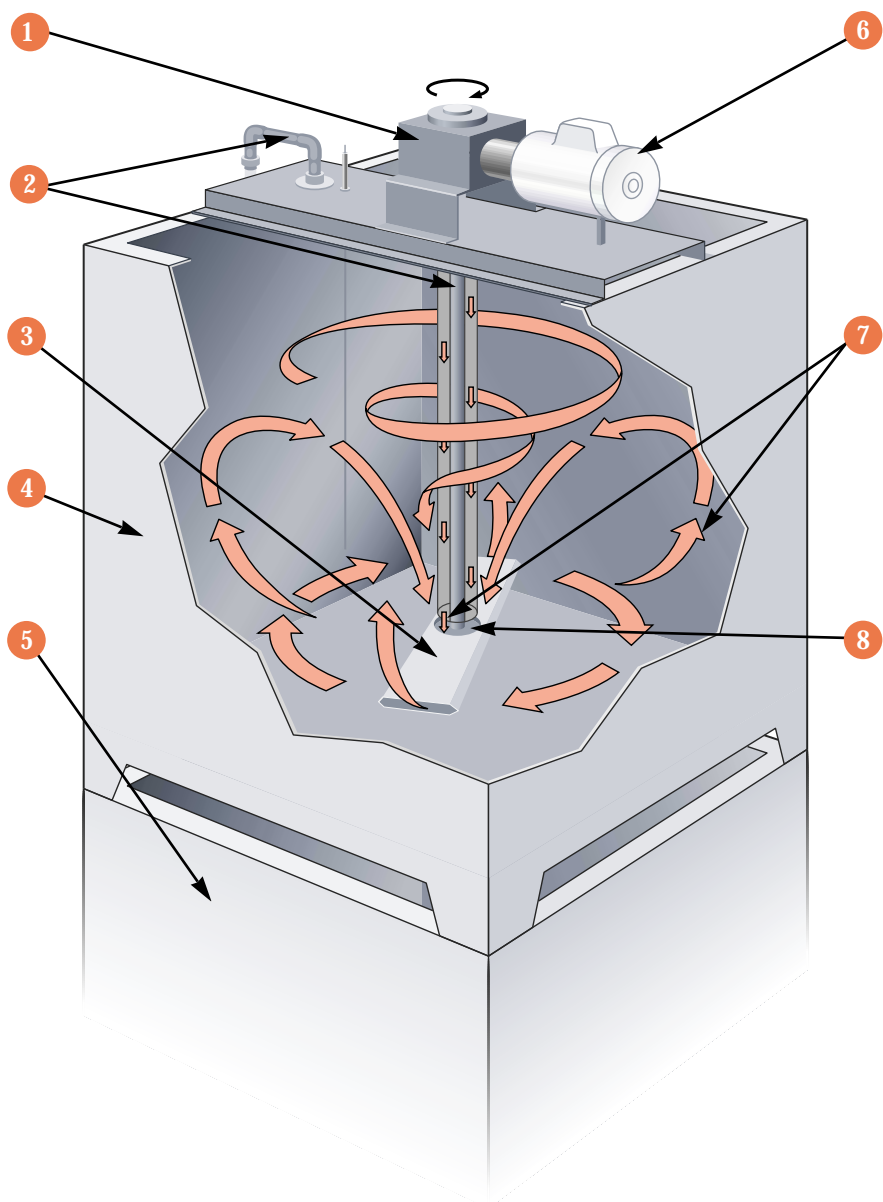

AUTOMATED OPERATION

1. **EXTENSION HOPPER**
See next page for handling choices.
2. **DRY POWDER FEEDER**
Provides accurate and repeatable feed rates within 1%.
3. **PNEUMATIC BALL VALVE**
Provides positive shut-off of the inlet water, even if the system loses power and/or air pressure.
4. **DRY DISPERSER**
Evenly dispenses polymer into solution to reduce waste and improve performance.
5. **INTEGRAL AIR COMPRESSOR**
Provides reliable air supply when clean air is unavailable.
6. **DIRECT DRIVE MIXING**
Provides quiet and troublefree operation.
7. **MONITORING GAUGE ASSEMBLY**
Provides immediate information on all critical system pressures.
8. **LIQUID POLYMER PUMP (OPTIONAL)**
Provides system with most flexibility to meet future needs.

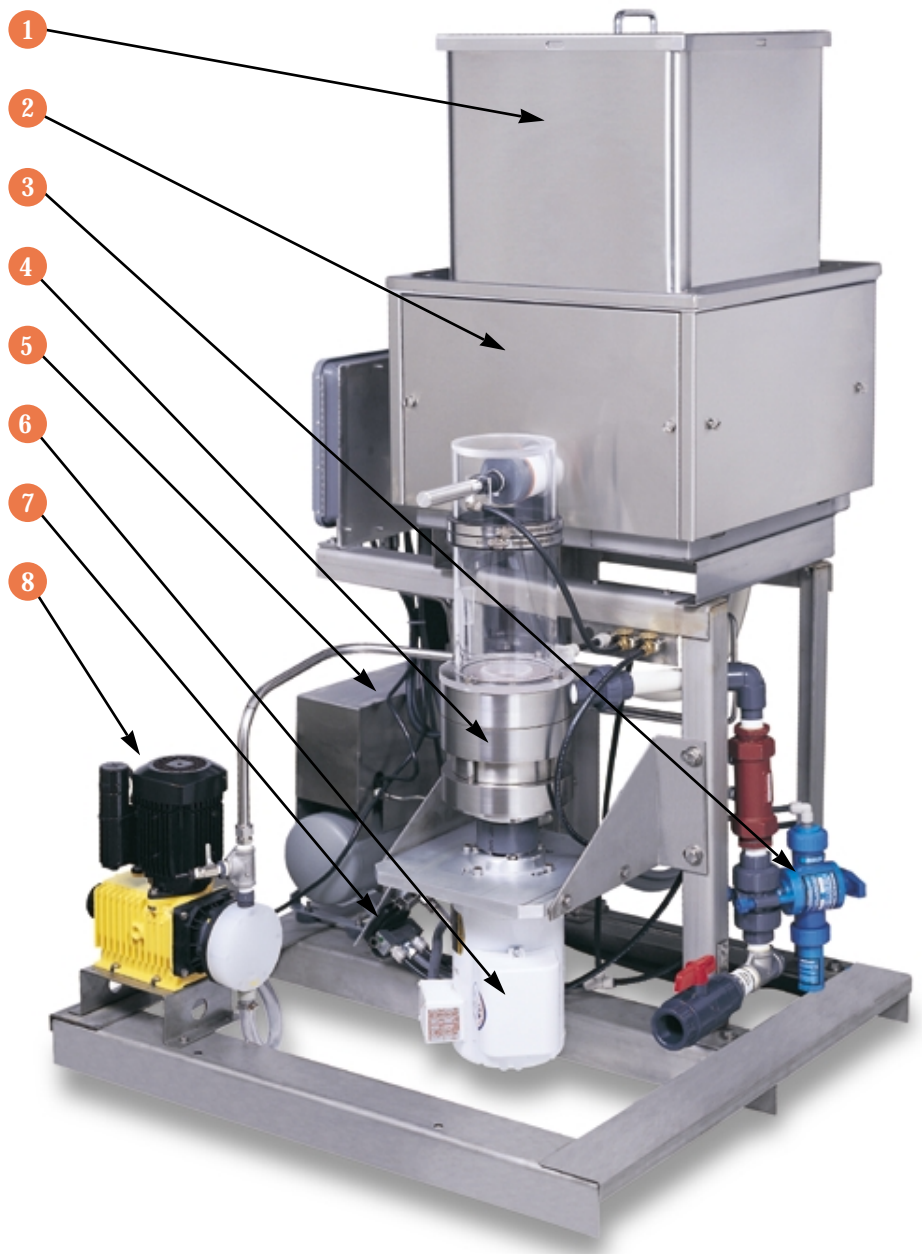

CHOICES TO MEET YOUR CRITERIA

<p>Dry Polymer Standard models make down from 6-94 lbs/hr depending on solution concentration and mixing time required.</p>	<p>Air Supply Plant System Integral Compressor</p>
<p>Emulsion/Dispersion Polymer Diaphragm Metering Pump 22 gph 35 gph Progressive Cavity Metering Pump 10 gph 50 gph</p>	<p>Voltage 208/1/60 VAC/phase/Hz 240/1/60 VAC/phase/Hz 480/3/60 VAC/phase/Hz 575/3/60 VAC/phase/Hz</p>
<p>Mannich Polymer Stainless Steel Gear Metering Pump 60 gph 200 gph 660 gph</p>	<p>Dry Polymer Handling 2.5 ft³ Hopper 20 ft³ Hopper Bulk Bag Frame Bulk Bag Frame with Hoist Bag Dump Hopper Other Combinations</p>
<p>Batch Tanks 160 Gallon – Single or Tandem 360 Gallon – Single or Tandem 750 Gallon – Single or Tandem 1500 Gallon – Single or Tandem</p>	<p>Options Low Powder Level Indication Over-sized Feeder Screw Supply Water Pressure Reducing Valve</p>
<p>Water Supply 20 gpm 30 gpm 100 gpm</p>	<p>Accessories Final Feed Pumps Final Feed Post-Dilution Large Hold Tanks Transfer Pumps</p>
	<p>Engineered Systems to Meet Your Design Criteria</p>