

PREMIA® 75

SOLENOID METERING PUMPS

MEGA AND MICRO SERIES

Key Features – Mega Series

- 20 sizes to cover a range of capacities up to 21 gph (79 l/h) and pressures up to 300 psi (21 bar).
- Manual control by on-line adjustable stroke length and stroke frequency.
- Optional external control by 4-20 mA input or pulse input, with stop function.
- Auto degassing arrangements available up to 1.83 gph (6.94 l/h).
- 3 function valve supplied as standard.
- 100:1 turndown ratio.
- Metering performance reproducible to within ±2% of maximum capacity.
- Panel mounted circuit breaker and indicator lights.
- ETL certified for indoor and outdoor use per UL Standard 778, as well as CSA standard C22.2 and NSF Standard 50.

Key Features – Micro Series

- 20 sizes to cover a range of capacities up to 21 gph (79 l/h) and pressures up to 300 psi (21 bar).
- 16 character dot matrix back lit display for clear indication of operating conditions and alarms.
- Manual control by on-line adjustable stroke length and stroke frequency; stroke counting and timed interval operation also available.
- External control by 4-20 mA or 20-4 mA input or pulse input, with ratio control and stop function.
- Auto degassing arrangements available up to 1.83 gph (6.94 l/h).
- 3 function valve supplied as standard.



- 1000:1 turndown ratio in manual mode.
- Metering performance reproducible to within ±2% of maximum capacity.
- Panel mounted circuit breaker and indicator lights.
- ETL certified for indoor and outdoor use per UL Standard 778, as well as CSA standard C22.2 and NSF Standard 50.

OPERATING BENEFITS

Reliable Metering Performance

Guided check valves, with state-of-the-art ball and seat designs, provide precise seating and excellent priming and suction lift characteristics. The timing circuit is virtually unaffected by temperature, EMI and other electrical disturbances.

Rated for Continuous Duty

Premia®75 pumps continue to meet their capacity and pressure specifications even during extended use. The solenoid is separately encapsulated in a

fin-cooled, thermo-conductive enclosure that effectively dissipates heat.

High Viscosity Capability

A straight flow path, and ample clearance between the diaphragm and head, enable the Mega and Micro to handle viscosities up to 10,000 CPS.

High Specification Liquid End

The premium composite diaphragms are manufactured to stringent specifications to ensure long life, even under the most demanding applications. The design incorporates teflon-facing and fabric reinforcements, bonded to a preformed elastomeric support which combined with an integral o-ring for complete sealing and a metal insert will ensure volumetric accuracy even at varying discharge pressures.



TOTAL SOLUTIONS

Included as standard accessories are a 3 function valve (for capacities up to 10 gph), injection valve, foot valve/sinker/strainer, tubing and tubing straighteners.

A Wide Range of Additional Accessories is Available

Choose from tank feed systems, mixers, flow meters, liquid level controllers, flow indicators, wall mounting brackets, and many more. Reference publication

TI460.150 UA for additional information.

Quick and Economical Liquid End Maintenance

A unique PM Kit™ is available for every model. These convenient, economically priced packages contain new cartridge check valves, diaphragm,

PUMP TECHNICAL DATA

Capacity and Back Pressure - MEGA (ME) and MICRO (MP) Series

Back Pressure, maximum psig (bar)	Capacity, nominal US gph (l/h)								
	0.13 (0.49)	0.20 (0.79)	0.25 (0.95)	0.45 (1.73)	0.50 (1.89)	0.58 (2.20)	0.83 (3.15)	0.87(3.31)	1 (3.78)
300 (21)	00								
250 (17)		01		02			03		
150 (15)			H1		H2			H3	
100 (7)					M2	M3			M4

Back Pressure, maximum psig (bar)	Capacity, nominal US gph (l/h)									
	1.66 (6.31)	1.75 (6.62)	1.83 (6.94)	2.5 (9.5)	3.12 (11.83)	3.91 (14.82)	5.0 (18.93)	8.0 (29.96)	10.0 (37.85)	20.83 (78.85)
250 (17)	06									
150 (10)		H7		10	12					
100 (7)			M7			15	19			
50 (3.3)								30		
35 (2.4)									38	
20 (1.3)										79

TECHNICAL DATA

Pump Technical Data *Continued*

	Mega	Micro
Materials of Construction Pump Head	Glass-filled Polypropylene (GFPPL), Polyvinylidene Fluoride (PVDF), Styrene-Acrylonitrile (SAN), PVC, 316 SS	
Diaphragm	Teflon-faced, Fabric-reinforced, Hypalon-backed, metal insert	
Check Valves: Seats/O-rings Balls Fittings	Teflon, Hypalon, Viton Ceramic, Teflon, 316 SS, Hastalloy C GFPPL, PVDF, PVC, 316 SS	
Injection Valve/Foot Valve	Same as fittings and check valves selected	
Tubing: Suction Discharge	4 feet clear PVC 8 feet white polyethylene (PE) Tubing may also be supplied in PVDF, polypropylene or black UV-inhibited PE	
Connections Tubing	$\frac{1}{4}$ " ID x $\frac{3}{8}$ " OD $\frac{3}{8}$ " ID x $\frac{1}{2}$ " OD	$\frac{1}{2}$ " x $\frac{3}{4}$ " OD - Model 79 only
Piping	$\frac{3}{16}$ " ID x $\frac{5}{16}$ " OD - capacities to 0.50 gph $\frac{1}{4}$ " FNPT $\frac{1}{2}$ " FNPT	
Reproductibility at Max. Capacity	±2%	
Maximum Viscosity	10,000 CPS with spring loaded ball check valves Viscosities measured with a Brookfield Viscometer, No. 2 and No. 3 spindles, 1.5 RPM	
Maximum Stroke Frequency	125 SPM	
Stroke Length Turndown Ratio	10:1	
Stroke Frequency Turndown Ratio	10:1	100:1
Maximum Suction Lift at 1 CPS	10 feet (3.1 meters) once primed	
at 3000 CPS	3.5 feet (1.1 meters) once primed	
Power Input	115 VAC, 50/60 Hz, 1 Ph, 230 VAC, 50/60 Hz, 1 Ph	
Average Input Power @ Max. SPM	130 Watts	
Average Current Draw	@ 115 VAC – 1 Amp, @ 230 VAC – 0.5 Amps	
Peak Input Power	300 Watts	
Signal Relay	N/A	24 VDC, 10 mA
Power Relay	N/A	250 VAC, 50/60 Hz, 0.5 Amps
Maximum Temperature	104°F (40°C)	

OPTIONAL 5 FUNCTION VALVE TECHNICAL DATA

Materials of Construction Valve Body	GFPPL, PVDF
Diaphragm	Teflon-faced Hypalon
O-rings	Teflon
Hardware	18/8 SS
Maximum Operating Pressure	250 psi (17 bar)
Maximum Flow	10 gph (37.85 l/h)
Maximum Viscosity	1000 cP, Measured with a Brookfield Viscometer, No. 2 and No. 3 spindles, 1.5 RPM
Pressure Relief Setting	275 psi (19 bar) – coded red 175 psi (12 bar) – coded green 125 psi (8.6 bar) – coded blue
Connections Tubing	$\frac{1}{4}$ " ID x $\frac{3}{8}$ " OD $\frac{3}{8}$ " ID x $\frac{1}{2}$ " OD For other connections consult W&T
Piping	$\frac{1}{4}$ " MNPT
Relief Port	$\frac{1}{4}$ " ID x $\frac{3}{8}$ " OD $\frac{3}{8}$ " ID x $\frac{1}{2}$ " OD $\frac{1}{4}$ " MNPT (with NPT connection only)

Teflon, Hypalon and Viton are Registered Trademarks of E.I. DuPont Company.

DIMENSION AND SHIPPING WEIGHTS

Notes

- Pump heads in 316 SS and PVDF are not available with capacity selection 79.
- Optional 5 function valve is not available on auto degassing arrangements, >1000 CPS arrangements, or capacity selection 79.
- Foot valve/strainer is not available on >3000 CPS arrangements.
- Auto degassing liquid end is only available with PVC head, ceramic balls, Viton seals/o-rings and 5/16" OD suction tubing and 3/8" OD discharge tubing.
- Pump heads in SAN are not available on models rated above 100 psi (7 bar).
- Pump heads in PVC are not available on models rated above 150 psi (10 bar).

For technical information on the Premia[®]75 solenoid metering pump Mono and Econo Series request publication TI 460.150-1UA.

For technical information on the Premia[®]75 solenoid metering pump Mini and Mini-DC Series request publication TI 460.150-2UA.

For information on Premia[®]75 solenoid metering pump accessories request publication TI 460.150-4UA.

For chemical resistance guidelines request publication TI 460.150-6UA.

For ordering information request publication TI 460.150-5UA.

Mega/Micro Agency Listing



MEGA	MICRO	Dimensions (inches)							Shipping Weight (lbs.)
		A	B	B1	C	C1	D	E	
ME00	MP00	5.4	12.7	-	11.3	-	7.5	9.5	13
ME01	MP01	5.4	12.7	-	11.3	-	7.5	9.5	13
ME02	MP02	5.4	13	-	11.7	-	7.5	9.7	15
ME03	MP03	5.4	13	-	12.2	-	7.5	9.7	18
ME06	MP06	6.2	13.4	-	11.7	-	8.2	10.1	21
MEH1	MPH1	5.4	12.7	-	11.3	-	7.5	9.5	13
MEH2	MPH2	5.4	13	-	11.2	-	7.5	9.7	13
MEH3	MPH3	5.4	13	-	11.7	-	7.5	9.7	15
MEH7	MPH7	5.4	13	-	12.2	-	7.5	9.7	18
ME10	MP10	5.4	13.4	-	12.2	-	7.5	10.1	18
ME12	MP12	6.2	13.7	-	11.7	-	8.2	10.5	21
MEM2	MPM2	5.4	12	-	11.2	-	7.5	9.7	13
MEM3	MPM3	5.4	13	-	11.2	-	7.5	9.7	13
MEM4	MPM4	5.4	13	-	11.2	-	7.5	9.7	13
MEM7	MPM7	5.4	13	-	11.7	-	7.5	9.7	15
ME15	MP15	5.4	13.4	-	12.2	-	7.5	10.1	18
ME19	MP19	6.2	13.7	-	11.7	-	8.2	10.5	21
ME30	MP30	6.2	14.1	-	11.7	-	8.2	10.8	21
ME38	MP38	6.2	14.1	-	11.7	-	8.2	10.8	21
ME79*	MP79	6.2	-	10.9	-	10.6	8.2	-	25

*The ME79 & MP79 are designed without a five function valve

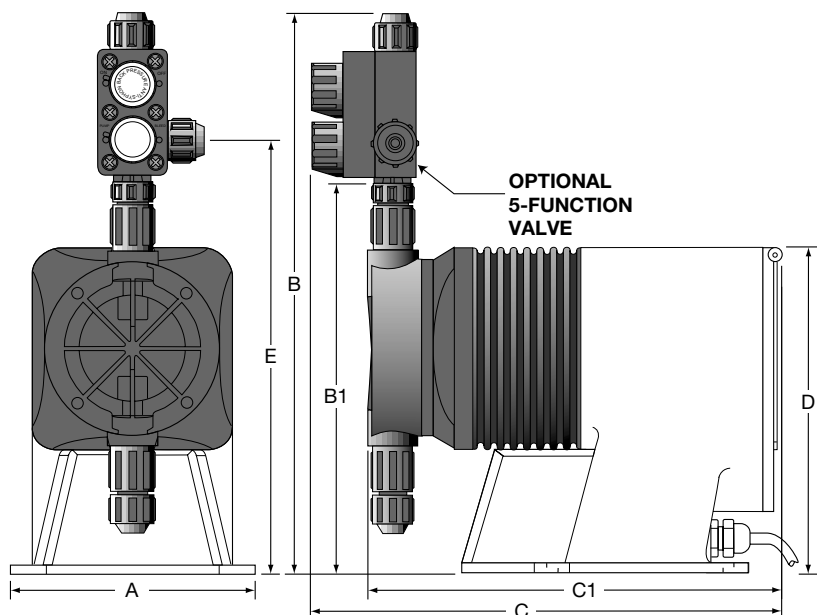

EQUIPMENT

SPECIFICATION

1.0 GENERAL

Chemical metering pumps shall be of the positive displacement, non-hydraulic, solenoid-driven, diaphragm type. Output shall be continuously rated at operating temperature, and adjustable while pumps are in operation. Positive flow shall be ensured by the use of a minimum of four ball type check valves and a 3 function valve. An optional 5 function valve is available for pressure relief, backpressure, anti-syphon, air bleed and discharge drain. The pump shall be water resistant for outdoor installation, and internally dampened for noise reduction. The pump shall be a Wallace & Tiernan Products Premia®75 (Mega), (Micro) Series.

2.0 PUMP CONTROL

2.1 Mega Series

The control panel shall be located opposite the liquid end. Capacity adjustment to be via dial knobs for stroke length and stroke frequency. Stroke length adjustment shall have a locking lever. Control functions to be manual (with external pulse input and stop) (with external 4-20 mA input and stop). For all operating modes, a green indicator light on the control panel shall illuminate when the pump is in operation, and strobe once for each pump stroke. Turndown ratio shall be 100:1.

Manual Control

Pump control to be selectable between on and off by means of a 2-position switch.

Pulse Input and Stop

Pump control to be selectable between manual and external by means of a 3-position switch. In external mode, the pump to accept dry contact closures. As contact closes, the pump shall stroke once, minimal contact closure time is 10 msec. Contact must open and close for each pump stroke. Maximum closures – 125 per minute. A dry contact closure to the stop function to cause the pump to halt operation and illuminate a red indicator light on the pump control panel, in either manual or external pacing mode. The pump shall resume normal operation when contact opens.

4-20 mA Input and Stop

Pump control to be selectable between manual and external by means of a 3-position switch. In external mode, the pump shall accept a direct 4-20 mA DC signal, without signal interface or conversion device. Internal resistance to be 124 ohms. A dry contact closure to the stop function shall cause the pump to stop operation and illuminate a red indicator light on the pump control panel, in either manual or external pacing mode. The pump to resume normal operation when the contact opens.

2.2 Micro Series

The control panel shall be located opposite the liquid end. Capacity adjustment to be via a dial knob for stroke length and a 6 button keypad for stroke frequency and function selection. Stroke length adjustment shall have a locking lever.

Control functions to include manual, external pulse input, 4-20 mA and 20-4 mA input, stroke counting, timed interval operation and stop. A single relay output shall be provided to allow for interfacing the pump with external equipment. The pump to have a 16 character dot matrix backlit LCD display to view control options, operating conditions and alarms. For all operating modes, a green indicator light on the control panel shall illuminate when the pump is in operation and strobe once for each pump stroke. In all operating modes, a red indicator light on the control panel to illuminate when pump operation is halted via the stop function.

Manual Control

Pump control shall be selectable between on and off using the 6 button keypad. Stroke rate to be adjustable from 1 to 100%.

Pulse Input

The pump shall have the capability of being paced by pulse rates up to 125 contacts per minute and be able to multiply or divide the incoming pulse signal

PREMIA® 75

SOLENOID METERING PUMPS

MEGA AND MICRO SERIES

Equipment Specifications continued

by a factor of 1 to 999. The pump to have a pulse storage option for signals which have frequencies greater than 125 contacts per minute, with storage of up to 9999 contacts. The pump shall work off the pulses in memory at maximum stroking rate, when signal drops below 125 contacts per minute.

Stroke Counting

The pump to be capable of delivering a preset number of strokes, up to 999, at a selected stroke rate from 1 to 100%.

Timed Interval Operation

The pump shall be capable of operating for selected run times from 1 to 999 seconds, at selected intervals from 1 to 999 minutes, at a selected stroke rate from 1 to 100%.

Stop

A volt free contact closure to the stop function to cause the pump to stop operation, in either manual or automatic mode, and illuminate a red indicator light on the pump control panel. The pump shall resume normal operation when the contact opens.

Relay Outputs

The pump to be equipped with (a signal level relay, rated at 24 VDC, 10 mA), (a power level relay, rated at 250 VAC, 0.5 Amps). The relay shall be normally open. Relay closure to occur for the alarm or condition selected using the 6 button keypad.

3.0 Electronic Drive

To prevent damage to the pump from over heating, the solenoid shall have automatic reset thermal overload protection. For overpressure conditions, the pump shall automatically stop pulsing when discharge pressure exceeds pump pressure rating by not more than 35%, when the pump is at maximum stroke rate.

The electronic circuitry shall be EMI resistant and shall employ a metal oxide varistor for lightning protection.

A resettable circuit breaker mounted on the pump control panel, accessible from the outside of the pump, shall provide circuit overload protection.

Internal wiring between electronic circuit board, solenoid and power shall be quick disconnect terminal at least 3/16" wide.

4.0 Enclosure

The pump drive shall be encased in a water resistant housing constructed of a chemically resistant glass-filled polyester. The electronic circuitry shall be mounted at the rear of the pump for maximum protection against chemical intrusion.



Wallace & Tiernan Products
 1901 West Garden Road
 Vineland, NJ 08360
 856.507.9000 *tel*
 856.507.4125 *fax*
www.wallaceandtiernan.usfilter.com
 Literature # TI 460.150-3 UA 9/99
 ©1999 United States Filter Corporation